



Galaxy Series[®]



Louvreclad's Galaxy Series[®] is an operable louvre system that provides a ready-made solution for both natural and fire ventilation purposes. This Louvre design can be operated via manual handles but is more commonly operated via pneumatic cylinders or electric actuators. A spring to open/close configuration is available with thermal links to enable fail-safe operation for fire venting.

Distinctive Features + Diverse Applications + Multitude of Benefits:

- Automated or manual operation*
- Sheetmetal construction and available in steel, aluminium and stainless steel
- Optional powder coated and Colorbond[®] finish
- In the event of fire they can provide automatic smoke and heat exhaust or inlet ventilation

Attention to Detail:

- 85% free open area + fire-tested (AS2428.4)
- Heights are available from 570mm - 5938mm
- Can be interconnected with fire control systems
- When specifying opening size for Galaxy wall louvres, add 15mm to the width and height of the louvre
- Tested and certified for co-efficient of discharge 0.831
- Mass/m² = 10.5kg (Aluminium)

Attention to Detail:

- Co-efficient of discharge = 0.831
- Designed and manufactured to comply with AS 2427-1983:
 - *Rain leakage wind velocity*
 - *Maximum wind velocity for operation*
 - *Structural adequacy*
 - *Corrosion resistance*
 - *Operation under snow loading*
- Tested and certified to satisfy AS 2428-1983:
 - AS 2428.1 - *Determination of resistance to leakage during rain*
 - AS 2428.2 - *Determination of ability to operate under wind loading*
 - AS 2428.3 - *Determination of operating characteristics*
 - AS 2428.4 - *Determination of the effect of flame contact*
 - AS 2428.5 - *Determination of discharge co-efficient and effective aerodynamic area*
 - AS 2665-1983 - *Smoke/heat venting systems*

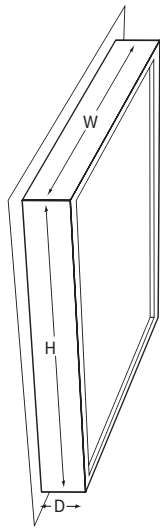

Technical Specifications

Series	Ventilator Width	Ventilator Height	Ventilator Depth	Number of Blades	Weight	Ventilator Throat Area	EAA-Effective Aerodynamic Area
	mm	mm	mm		kg	m ²	m ²
Galaxy 1012	1000	1180	220	9	30	0.931	0.773
Galaxy 1018	1000	1790	220	14	40	1.477	1.227
Galaxy 1024	1000	2400	220	19	51	2.023	1.681
Galaxy 1030	1000	3010	220	24	61	2.569	2.135
Galaxy 1112	1100	1180	220	9	32	1.035	0.860
Galaxy 1118	1100	1790	220	14	42	1.642	1.364
Galaxy 1124	1100	2400	220	19	53	2.249	1.869
Galaxy 1130	1100	3010	220	24	64	2.856	2.373
Galaxy 1212	1200	1180	220	9	33	1.139	0.946
Galaxy 1218	1200	1790	220	14	45	1.807	1.501
Galaxy 1224	1200	2400	220	19	56	2.475	2.056
Galaxy 1230	1200	3010	220	24	67	3.143	2.612
Galaxy 1312	1300	1180	220	9	35	1.243	1.033
Galaxy 1318	1300	1790	220	14	47	1.972	1.639
Galaxy 1324	1300	2400	220	19	58	2.701	2.244
Galaxy 1330	1300	3010	220	24	70	3.430	2.850
Galaxy 1412	1400	1180	220	9	37	1.347	1.119
Galaxy 1418	1400	1790	220	14	49	2.137	1.776
Galaxy 1424	1400	2400	220	19	61	2.927	2.432
Galaxy 1430	1400	3010	220	24	73	3.717	3.089
Galaxy 1512	1500	1180	220	9	38	1.451	1.206
Galaxy 1518	1500	1790	220	14	51	2.302	1.913
Galaxy 1524	1500	2400	220	19	63	3.153	2.620
Galaxy 1530	1500	3010	220	24	76	4.004	3.327

Blade pitch is 122 mm.

DRAFT SPECIFICATION

Wall Louvre Ventilators will be Louvreclad Galaxy Series[®] with [width x length] with a coefficient of discharge of no less than 0.831, designed and manufactured to comply with AS 2427-1983, and tested and certified to satisfy AS 2428-1983.

Base Material & Finish

Ventilators will be manufactured in [select base material] finish in [select colour]

Accessories

[Nominate options/accessories from the selection].

Installation and Mounting

Installation and mounting details will be designed in accordance with proprietary systems and recommendations as designed and manufactured by Louvreclad Pty. Ltd. Phone: 1300 165 678 Email: sales@louvreclad.com

Base Material Options

- Zinalume[®]
- Colorbond[®]
- Galvabond[®]
- Aluminium

Finishes Available

Choose from the following range of finishes:

- complete Colorbond[®] range of colours and types

Accessories

Bird/Vermin Mesh

Select from the following:

- galvanised
- stainless steel
- PVC

Operating Options

- Electric actuator
- Pneumatic cylinder

** Manual hand operation options [on Louvreclad operable Louvres] is only available when the louvres are accessible from behind.*

PROFILES

Galaxy Series[®] louvre 220mm frame

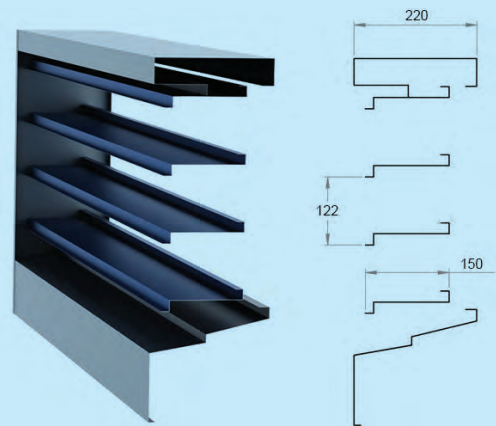

Galaxy Series[®] louvre 150mm frame

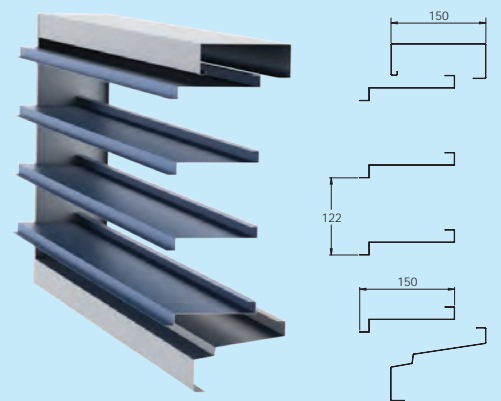

WOULD YOU LIKE TO KNOW MORE?

If you have any questions about this product, or if you would like to speak to a member of our expert team about how we can tailor a solution for you, call: **1300 165 678** or visit: louvreclad.com